



ROVESCIATORE IDRAULICO

Hydraulic tipper

CM 165 FLAP PFR



Rovesciatore idraulico con forche regolabili per bins di tutte le misure

- Applicabile a tutti i carrelli elevatori
- Portata 1500 kg
- Portata in rovesciamento 1200 Kg
- Sistema di bloccaggio brevettato
- Forche regolabili per contenitori di varie misure
- Valvola di sequenza per rovesciare con un solo comando
- Aggancio/sgancio rapido e tubi di connessione

Ideale per il rovesciamento di bins nel settore ortofrutticolo e alimentare

Hydraulic tipper with adjustable forks for bins of several sizes

- *Applicable to all forklift trucks*
- *Capacity 1500 kg*
- *Overturning capacity 1200 Kg*
- *Patented locking system*
- *Adjustable forks for bins of several sizes*
- *Sequence valve to overturn with a single control*
- *Quick hooking/unhooking and connection hoses*

Ideal for overturn bins with foodstuffs, fruit and vegetables

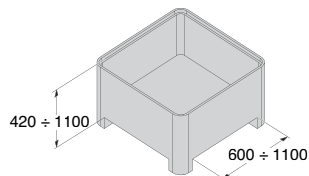

Forche in posizione aperta
Forks in open position



Forche in posizione chiusa
Forks in closed position

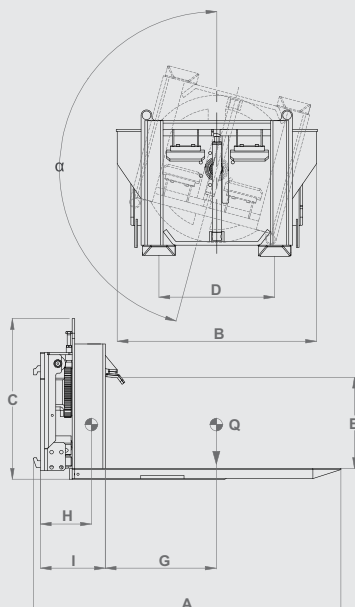

CM 165 FLAP PFR

Modello - Model		CM 165 FLAP PFR	
A	Lunghezza - Length	mm	1450
B	Larghezza - Width	mm	930
C	Altezza - Height	mm	750
D	Interasse forche - Fork base	mm	450 ÷ 750
E	Altezza contenitori - Height of containers	mm	420 ÷ 1100
H	Baricentro senza carico - Barycentre without load	mm	280
G	Baricentro del carico - Barycentre of the load	mm	500
I	Spessore - Thickness	mm	350
α	Angolo di rovesciamento - Overturning angle	°	165
Q	Portata - Capacity	Kg	1500
-	Portata in rovesciamento - Overturning capacity	Kg	1200
-	Pressione di esercizio - Operating pressure	bar	140
-	Peso - Weight	Kg	327
-	Linee idrauliche necessarie - Required hydraulic lines	n.	2 (1 leva d.e.) (1 d.c. lever)
-	Forche regolabili - Adjustable forks		130x40 L=1080