



# HYDRAULIC LOAD STABILIZER CM 16 STRFC

## Hydraulic load stabilizer for bins and cases

It can be applied to all forklift trucks, telehandlers and front loaders. It allows the blocking and stabilization of the load to carry out safely all the handling and warehousing operations.

- 1600 kg capacity
- FEM/ EURO linkage
- Pliable and adjustable steel forks
- Hydraulic connecting hoses

Available in the versions:

- One central cylinder (850/1100)
- Two hiding lateral cylinders (1150)
- Two central cylinders and extralifting (1700)
- With lateral side shift (TR)

Optional accessories: bin holder, case holder, multi-bin flaps.

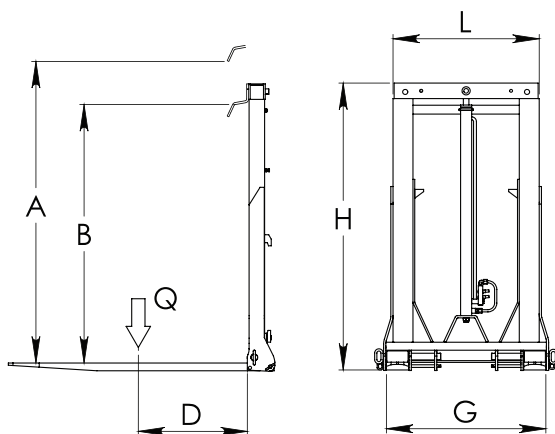

Version	BIN HOLDER			CASE HOLDER			L mm	H mm	G mm	D mm	P kg	TR	F
	Q kg	B mm	A mm	B mm	A mm								
850	1600	1160	1950	1100	1900	660	1300	490/720	500	191	-	1	
1100	1600	1460	2500	1400	2450	660	1600	490/720	500	198	-	1	
1150	1600	1460	2550	1400	2500	660	1600	490/720	500	215	-	1	
1700	1600	1100	2740	1050	2700	660	1250	490/720	500	219	-	1	
850 TR	1600	1160	1950	1100	1900	660	1300	490/720	500	261	100 + 100	2	
1100 TR	1600	1460	2500	1400	2450	660	1600	490/720	500	268	100 + 100	2	
1150 TR	1600	1460	2550	1400	2500	660	1600	490/720	500	285	100 + 100	2	
1700 TR	1600	1100	2740	1050	2700	660	1250	490/720	500	289	100 + 100	2	

**LEGEND:** (B) Minimum opening - (A) Maximum opening - (L) Frame width - (H) Overall dimensions - (G) Width with forks  
(D) Barycentre of the load - (P) Weight - (TR) Side shift - (F) Required hydraulic functions